



State Road (SR) 844 / 14th Street Causeway Bridge Painting Project

over the Intracoastal Waterway

Financial Project ID: 441473-1-52-01

Virtual Public Meeting
September 22, 2021

Agenda

- 1. Introductions**
- 2. Meeting Format**
- 3. Non-Discrimination Policy**
- 4. Rules of Engagement**
- 5. Project Overview**
- 6. Project Improvements**
- 7. Traffic Impacts**
- 8. Proposed Bridge Color**
- 9. What to Expect**
- 10. Sealed Work Zone**
- 11. Dust Control & Air Quality Monitoring**
- 12. Community Outreach**
- 13. Questions and Answers**
- 14. Contact Information**

Project Team



Saira Rothschild, P.E.
Project Manager
FDOT



Andres Atehortua
Project Administrator
AE Engineering, Inc.



Ricardo Baraybar, P.E.
Sr. Project Engineer
AE Engineering, Inc.



Angel Gardner
Community Outreach Specialist
Valerin Group, Inc.

Project Team



Helen James, P.E.
Design Project Manager
FDOT



Luis P. Ramos, P.E.
Engineer of Record
HNTB Corporation



Savvas Damalos
Seminole Equipment, Inc.



Tim N. Meris
Seminole Equipment, Inc.

Meeting Format

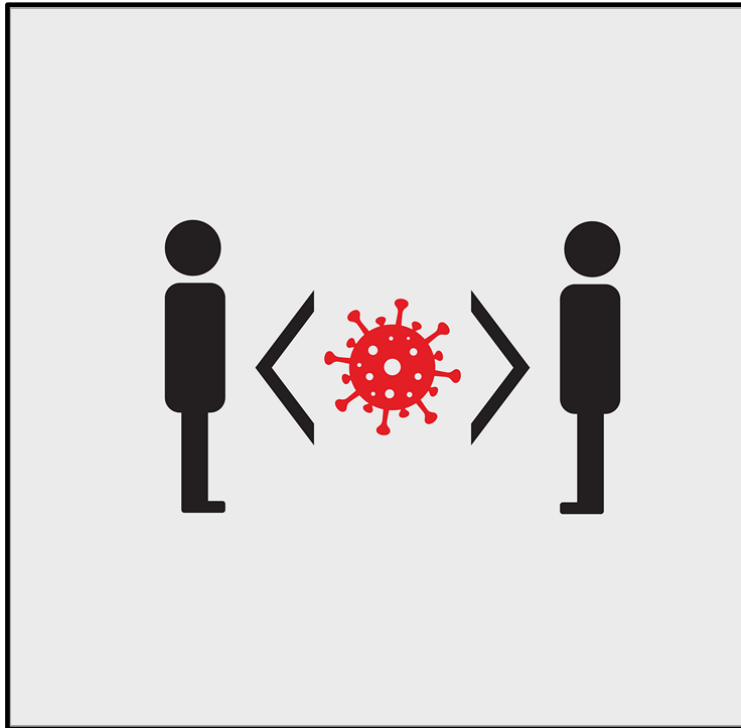

Online:

- 5:30 p.m. to 6:30 p.m.

In-Person:

- 6:30 p.m. to 7:30 p.m.
- Emma Lou Olson Civic Center
1801 NE 6th Street
Pompano Beach, FL 33060

Participating on GoToWebinar

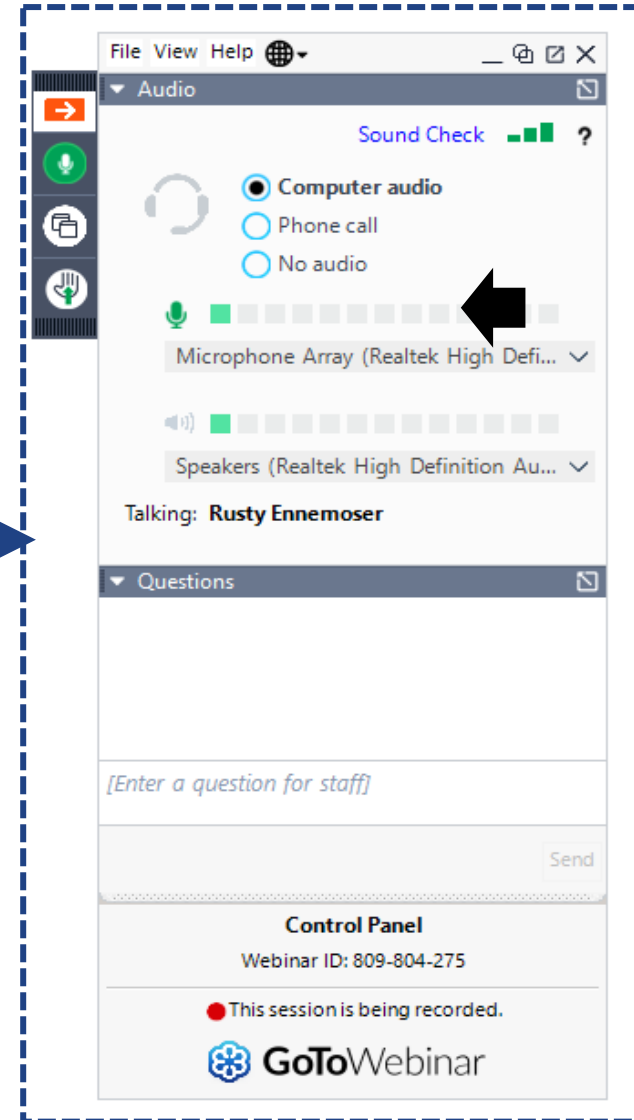

Virtual Public Meeting - Public Notice

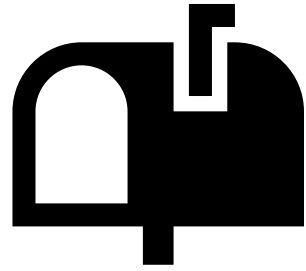

Property Owner/Tenant Letters



Social Media

@myFDOT_SEFL and @myFDOTSEFL

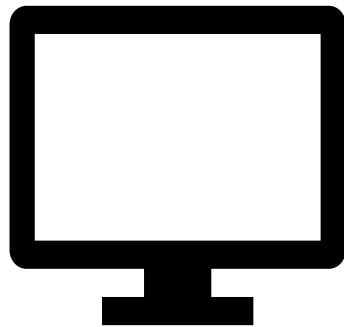

FDOT Website



Florida Administrative Register

The Florida Department of Transportation complies with various non-discrimination laws and regulations, including:

Title VI of the Civil Rights Act of 1964

This meeting is being held without regard to race, color, national origin, age, sex, religion, disability, or family status.

For questions or concerns, you may contact either:

District Four

Florida Department of Transportation
District 4 Title VI Coordinator

Sharon SinghHagyan

 3400 West Commercial Boulevard
 Fort Lauderdale, Florida 33309

 (954) 777-4190

 Sharon.SinghHagyan@dot.state.fl.us

Tallahassee Office

Florida Department of Transportation
State Title VI Coordinator

Jacqueline Paramore

 605 Suwannee Street, MS 65
 Tallahassee, Florida 32399

 (850) 414-4753

 Jacqueline.Paramore@dot.state.fl.us

Rules of Engagement



- This Virtual Public Meeting is being recorded.
- If you experience technical difficulties, please contact **GoToWebinar Support at +1 (833) 851-8340**.
- All attendees **will remain muted** throughout this Virtual Public Meeting.
- Attendees are also welcome to submit any questions/comments using the GoToWebinar Question Panel at any time and a member of the team will respond during the question-and-answer portion. To request to speak, click the Raise Hand button on the Control Panel and unmute your microphone when your name is called.

Project Overview

Purpose: Routine Preventative Maintenance

Project Length: 351 feet

Project Limits: State Road (SR) 844 / 14th Street Causeway over the Intracoastal Waterway

Project Duration: 168 days (plus holidays and weather days)

Bridge Closure: Total of four weekends

Construction Begins: October 7, 2021

Anticipated Completion: Spring 2022

Construction Cost: \$1.07 million

Contractor: Seminole Equipment, Inc.



Project Improvements

- Pressure washing and painting the structural steel of the SR 844 / 14th Street Causeway bascule bridge (Bridge No. 860060) over the Intracoastal Waterway
- Pressure washing and painting the concrete portions of the bridge
- Refurbishing the span locks and other mechanical components of the bridge
- Painting the sidewalk and traffic railing



Areas To Be Painted

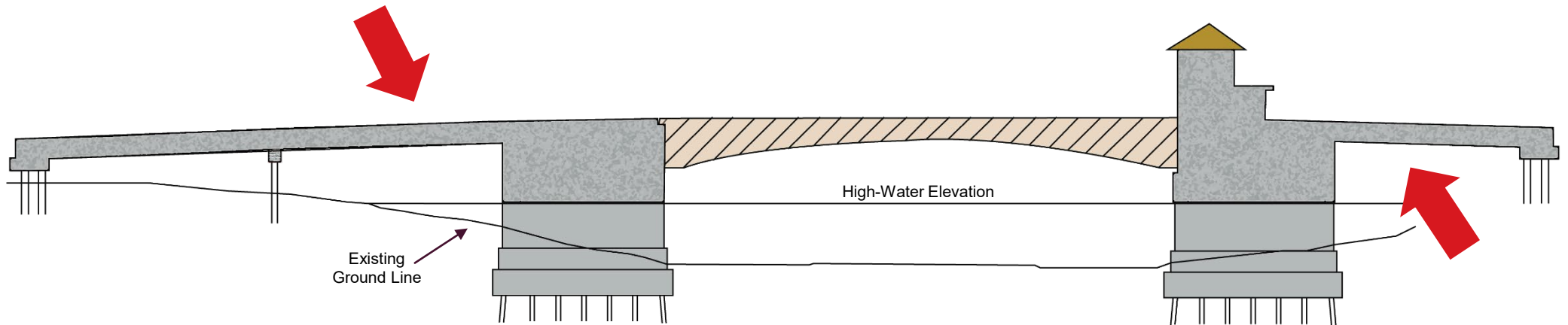
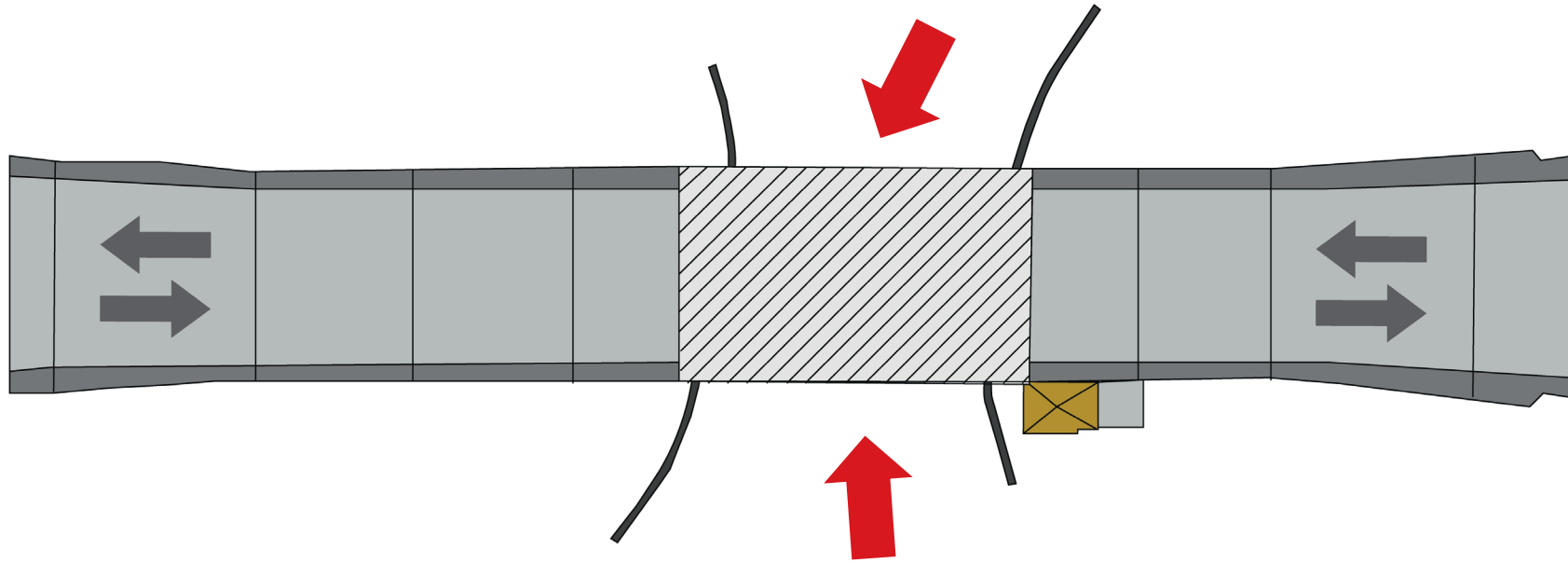

Proposed Bridge Color

State Road (SR) 844 / 14th Street Causeway Final Color will be Federal Color Standard 595B - No. 13740. See below for example.

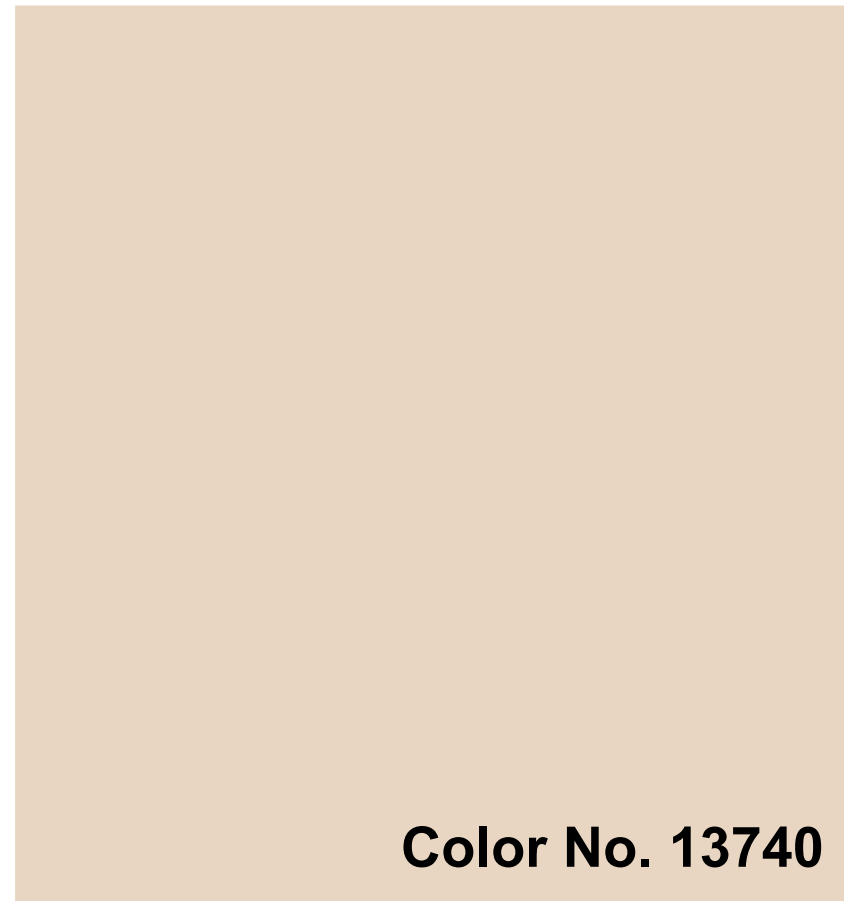

Color No. 13740

Traffic Impacts

- One lane in each direction may be closed at any time Sunday through Saturday.
- Full bridge closures for vehicle and pedestrian traffic will occur from 11 p.m. Friday to 8 a.m. Monday for a total of four weekends. Traffic will be detoured to SR 814 / Atlantic Boulevard and SR 810 / Hillsboro Boulevard.
- Access to adjacent properties will be maintained.
- Access to the Alsdorf Park Public Boat Launch and other community resources will be maintained.
- Marine traffic will be maintained through the navigable waterway. Channel restrictions may occur and will be published in the U.S. Coast Guard's Local Notice to Mariners.

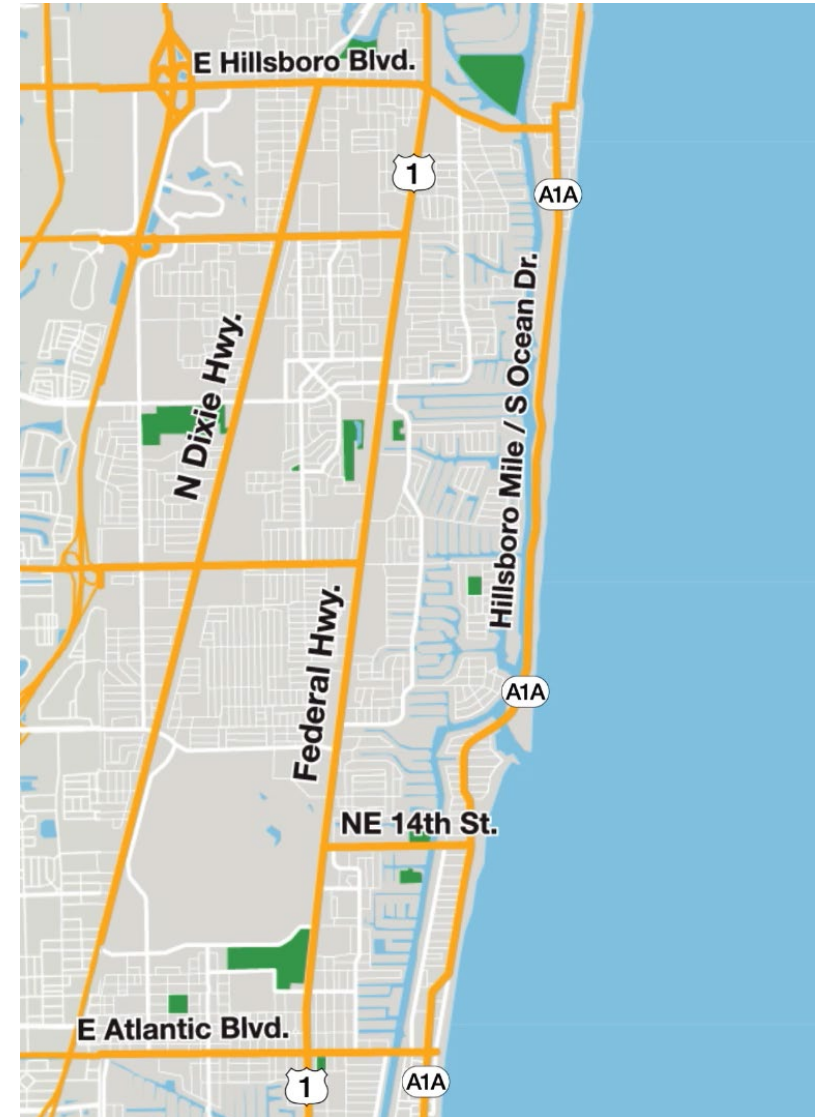

What to Expect

- Detour and work zone signage will be installed east and west of the bridge work zone.
- Complete seal of work zone (above and below bridge deck)
- Safe and controlled work area prevents paint materials and dust from entering the air
- Aids in noise control

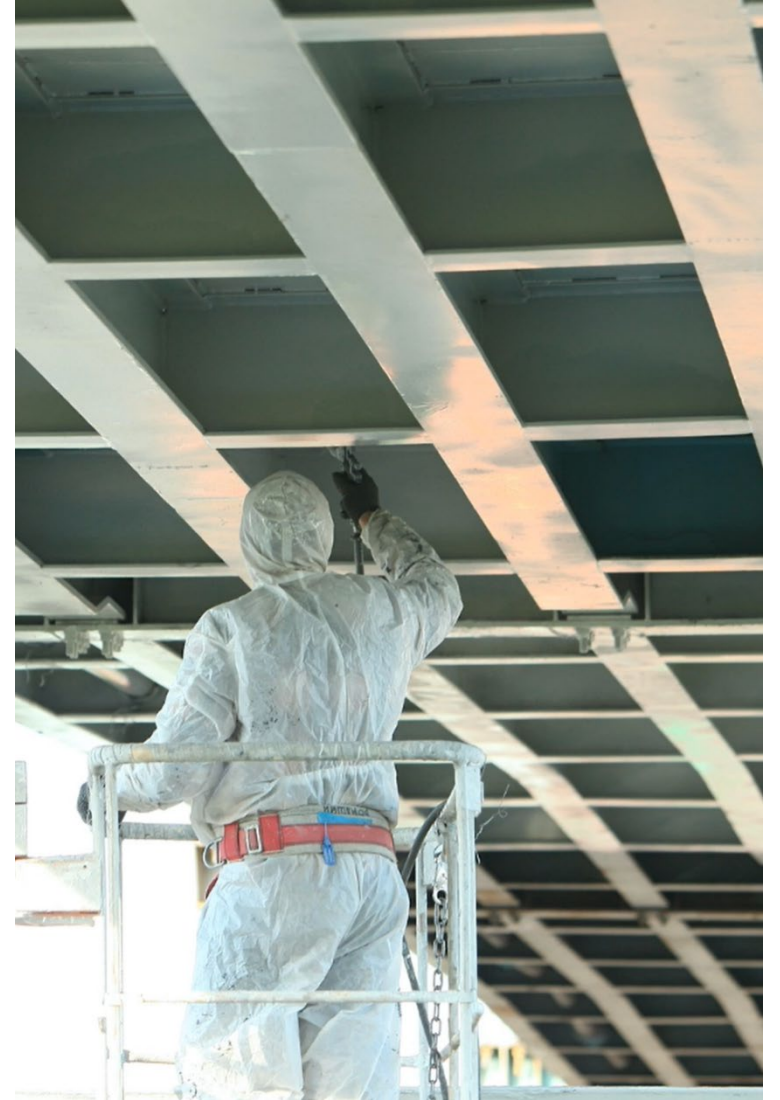

Sealed Work Zone

Areas Covered During Painting Operations

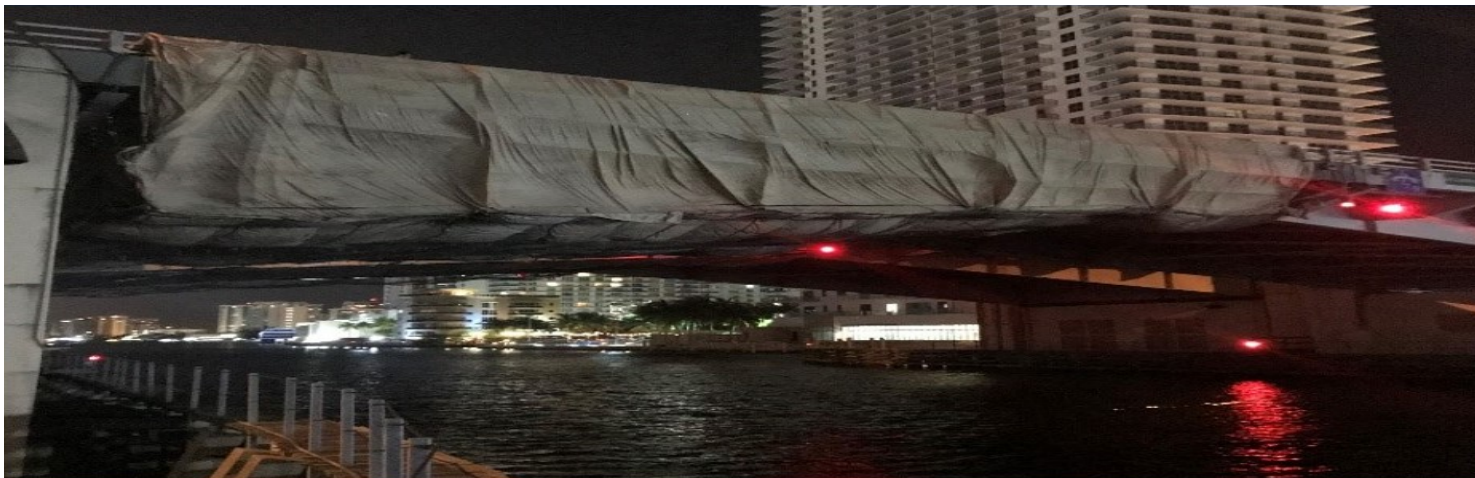
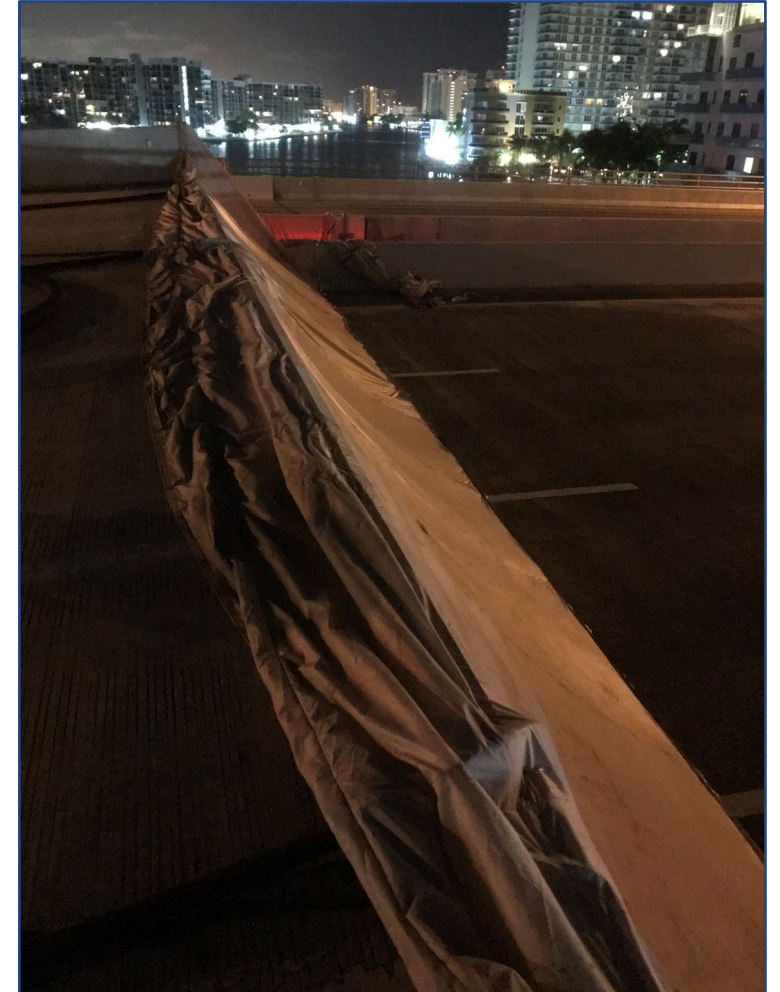

Dust Control & Air Quality Monitoring

- Monitoring occurs when an operation is likely to produce dust
- Measure dust levels in surrounding air to ensure that they are kept within the acceptable levels (US EPA 40 CFR 50)
- Monitors are placed in strategic locations that are most sensitive to dust and downwind of the painting operation to ensure emissions are properly controlled



Community Outreach

- The Community Outreach Specialist will distribute project update flyers via email and door-to-door as needed.
- Traffic impacts will be included in the FDOT District Four Communications Manager's Weekly Traffic Impact Press Release.
- The project team will meet with city/county officials, community groups and property owners regarding project updates as needed.

****All project updates will be posted to the District Four website and provided to the City of Pompano Beach****



Scan to reach the project website.

www.d4fdot.com



Scan to sign up for project updates.

<https://bit.ly/3jqljcZ>

Questions and Answers

- Attendees are welcome to submit questions/comments using the GoToWebinar Question Panel

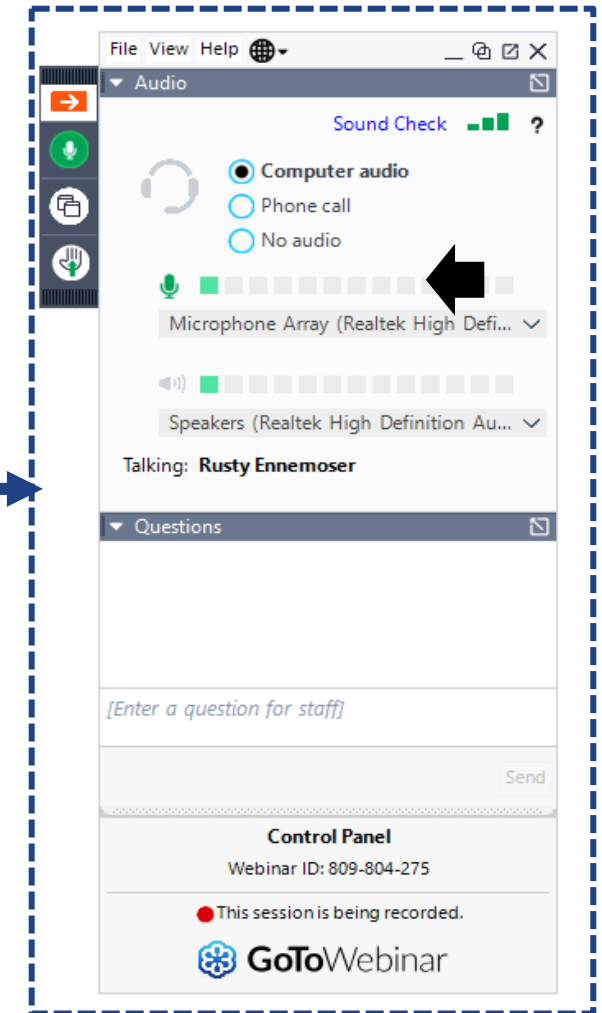

Additional Comments/Questions

Please submit your comments



If your question was not responded to during the event, our project team will follow up with you.

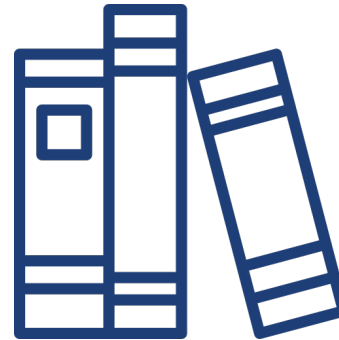

All comments and questions are part of the **Public Record.**

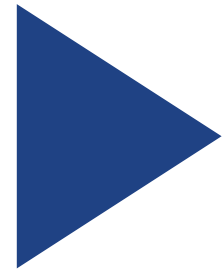

All registrants will receive a link to the **meeting recording and presentation slides.**

Contact Us

If you have additional questions, please contact the project team:

1. saira.rothschild@dot.state.fl.us



1. angel@valerin-group.com



2. (561) 531-0853



2. (561) 886-8773



1. aatehortua@aeengineeringinc.com



2. (786) 236-0791





**Thank you for attending tonight's
Virtual Public Meeting for the
State Road (SR) 844 / 14th Street Causeway
Bridge Painting Project!**